



CONCEPT DEVELOPMENT

Mathematics Assessment Project
CLASSROOM CHALLENGES
A Formative Assessment Lesson

Ferris Wheel

Mathematics Assessment Resource Service
University of Nottingham & UC Berkeley
Beta Version

For more details, visit: <http://map.mathshell.org>
© 2012 MARS, Shell Center, University of Nottingham
May be reproduced, unmodified, for non-commercial purposes under the Creative Commons license
detailed at <http://creativecommons.org/licenses/by-nc-nd/3.0/> - all other rights reserved

Ferris Wheel

MATHEMATICAL GOALS

This lesson unit is intended to help you assess how well students are able to:

- Model a periodic situation, the height of a person on a Ferris wheel, using trigonometric functions.
- Interpret the constants a , b , c in the formula $h = a + b \cos ct$ in terms of the physical situation, where h is the height of the person above the ground and t is the elapsed time.

COMMON CORE STATE STANDARDS

This lesson relates to the following *Standards for Mathematical Content* in the *Common Core State Standards for Mathematics*:

F-BF: Build a function that models a relationship between two quantities.
Build new functions from existing functions.

F-TF Model periodic phenomena with trigonometric functions.

This lesson also relates to the following *Standards for Mathematical Practice* in the *Common Core State Standards for Mathematics*:

4. Model with mathematics
7. Look for and make use of structure.

INTRODUCTION

It is helpful if students have met graphs of the sine and cosine functions before this lesson unit.

The unit is structured in the following way:

- Before the lesson, students attempt the assessment task individually. You then review their work and formulate questions for students to answer in order for them to improve their work.
- During the lesson, students engage in collaborative discussion in pairs or threes on a related task. They regroup to assess each other's work. Throughout their work they justify and explain their decisions to peers. In a whole-class discussion, students explain and extend their solutions and methods.
- Finally, students work alone again on a task similar to the assessment task.

MATERIALS REQUIRED

Each student will need a copy of the first assessment task: *Ferris Wheel*, the second assessment task, *Ferris Wheel (revisited)*, a scientific calculator (not a graphing calculator), a mini-whiteboard, a pen, and an eraser.

Each small group of students will need one copy of *Card Set A: Graphs*, *Card Set B: Functions*, *Card Set C: Descriptions of the wheels*, a large sheet of paper, a glue stick, and a pair of scissors. Some teachers cut the cards into sets before the lesson; others ask students to do this for themselves.

There are some projector resources to help with the discussions.

If you have to split the lesson over two teaching sessions, you will need some paper clips.

TIME NEEDED:

20 minutes before the lesson, a 90-minute lesson (or two shorter lessons), and 20 minutes in a follow-up lesson (or for homework). Timings approximate. Exact timings will depend on the needs of your class.

BEFORE THE LESSON

Assessment task: *Ferris Wheel* (20 minutes)

Set this task in class or for homework a few days before the formative assessment lesson. This will give you an opportunity to assess the work and identify students who have misconceptions, or need other forms of help. You should then be able to target your help more effectively in the follow-up lesson.

Give each student a copy of the task sheet, and a scientific calculator.

Have any of you been on a Ferris wheel?

About what diameter was it?

How fast did it turn?

Make sure students are familiar with the context. Then pose the problem:

On your own, I want you to answer the questions on the sheet.

Do as much as you can in 20 minutes.

Record all your thinking and calculations, so that I can follow your reasoning.

If there is anything you don't understand then please ask me.

It is important that, as far as possible, students answer the questions without assistance.

Advise your students they should not worry too much if they cannot do everything because you will teach a lesson using a similar task that should help them make progress. Explain that, by the end of the next lesson, they should expect to answer questions such as this one with confidence.

Assessing students' responses

Collect students' written work for formative assessment. Read through their scripts and make informal notes on what their work reveals about their current levels of understanding and their different problem-solving approaches.

Do not write grades on students' work. Research shows that this is counterproductive, as it encourages students to compare grades and compete with each other. That distracts them from focusing on how they could improve their mathematics.

To help students make further progress, write questions that focus attention on aspects of their work. Some suggestions for these questions are given on the next page. These have been drawn from common difficulties observed in trials of this unit.

We suggest you write your own lists of questions, based on your own students' work, using the ideas below.

You may choose to write questions on each student's work or, if you do not have time for this, just select a few questions that will help the majority of students. These can then be written on the board at the end of the lesson. These questions will guide students in improving their solutions.

The formative assessment activity will also inform your understanding of the issues your students need to work on during the lesson.

Ferris Wheel

A Ferris wheel is 60 meters in diameter and rotates once every four minutes. The centre axle of the Ferris wheel is 40 meters from the ground.

1. Using the axes below, sketch a graph to show how the height of a passenger varies with time. Assume that the wheel starts rotating when the passenger is at the bottom.

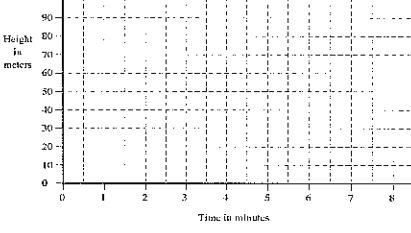

2. A mathematical model for this motion is given by the formula:

$$h = a + b \cos ct$$

where h = the height of the car in meters
 t = the time that has elapsed in minutes
 a, b, c are constants.

Find values for a, b and c that will model this situation.

Common issues:

Suggested questions and prompts:

<p>Graph is drawn, starting at the origin (Q1)</p>	<ul style="list-style-type: none"> • How high is the axle of the wheel? • How high is the person when she is in the bottom car?
<p>Graph consists of straight-line segments (Q1) For example: The points (0, 10), (60, 40), (120, 70) are joined with straight-line segments.</p>	<ul style="list-style-type: none"> • In which part of the ride is the passenger is rising most rapidly? How is this shown on your graph? • How does the vertical speed of the passenger change on your graph? • Describe what would happen to your height above the ground if you went on a ride like this.
<p>Constraints are not transferred correctly into graphical features (Q1) For example: The height of the axle - the central axis of the graph - is not shown as $h = 40$. Or: The rate of rotation is incorrect, as the graph is not shown as periodic every 4 minutes. Or: The diameter of the wheel – the peak-to-peak amplitude of the graph – is not shown as 60 meters.</p>	<ul style="list-style-type: none"> • What is the height of the axle? How does your graph show the height of the axle? • How long does it take for the wheel to complete one turn? How does your graph show the rate of rotation? • What is the diameter of the wheel? How does your graph show this diameter?
<p>Student does not interpret the given model (Q2) For example: The student rejects the use of cosine and adopts the sine function. Or: The student does not attempt to find values for a, b, c.</p>	<ul style="list-style-type: none"> • Which quantities vary as the Ferris Wheel turns? Which measures do not vary? • What do you know about the cosine function? • When is the cosine function zero? How does this connect to the motion of the Ferris Wheel?
<p>Student tries to find the values of variables by substitution, rather than analyzing the structure of the situation For example: The student attempts to substitute values of t and tries to solve for a, b and c: When $t = 0$, $a + b \cos(0c) = a + b = 10$. When $t = 4$, $a + b \cos(4c) = 10$. When $t = 2$, $a + b \cos(2c) = 70$.</p>	<ul style="list-style-type: none"> • What does c represent? • When $t = 4$, what is the value of the function? How do you know? What does this tell you about the rate of turn? • Think about the equation and structure of the physical situation. Which of a, b, or c would change if I raised or lowered the axis of the Ferris wheel? • Suppose the wheel turned more quickly. Which of a, b, or c would this change in the equation? • Suppose you had a Ferris wheel with a larger diameter. Which of a, b, or c would change? • How can these facts help you to fit the function to the graph?

SUGGESTED LESSON OUTLINE

Introduction: Transforming the cosine function (20 minutes)

Give each student a mini-whiteboard, a pen, and an eraser.

Begin the lesson by asking students use their mini-whiteboards to respond to questions. If at any stage students get stuck, offer a few more, similar, questions on those particular types of transformation.

For example, if they get stuck on $y = 2\cos x$, then look at $y = 3\cos x$, $y = 4\cos x$, and so on.

On your mini-whiteboards, sketch the graph $y = \cos x$.

What is its maximum value? [1]

What is the minimum value? [-1]

What is the period of the cosine function?

[After 360° the function values repeat.]

Where does it cross the x-axis?

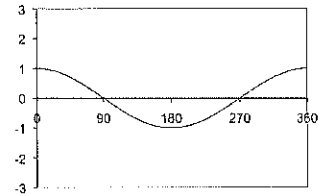

Now show me $y = 1 + \cos x$.

What is the maximum value? Minimum value? [2, 0]

What does adding the constant do to the graph of $y = \cos x$?

[Translates the graph +1 units vertically.]

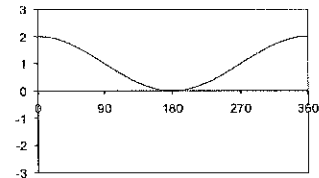

Show me $y = 2\cos x$.

What is the maximum value? Minimum value? [2, -2]

Where does the graph cross the x-axis?

What does multiplying by a constant do to the graph of $y = \cos x$?

[Stretch by factor of 2 parallel to y-axis.]

Has the period of the function changed? [No.]

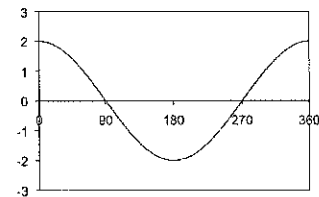

What about multiplying by -1? That gives $y = -\cos x$.

[This reflects the graph in x-axis.]

Has the period of the function changed? [No.]

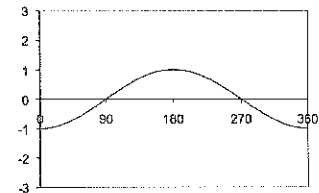

Show me $y = \cos 2x$.

What does multiplying the x by a constant do to the graph?

[Stretch parallel to x-axis.]

Is the period of this function different?

[Yes. The period is now 180 degrees.]

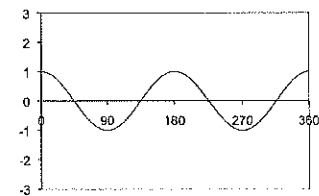

Try to combine some changes.

Show me $y = 1 + 2\cos x$.

What is the maximum value? Minimum value? [3, -1]

Where does this graph cross the x-axis? Estimate! [120°, 240°]

What has happened to the graph of $y = \cos x$?

[Stretched by a factor of 2 parallel to the y-axis, and translated +1 units vertically.]

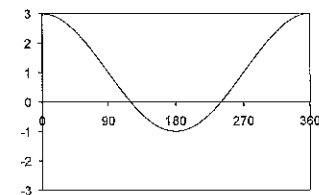

Now show me $y = 1 - \cos 2x$.

What is the effect if you combine multiplying by -1 , and multiplying the x by a constant?

[Stretch parallel to the x -axis, with a reflection of the graph in the x -axis.]

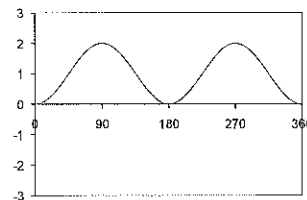

Throughout this activity, encourage students to articulate their reasoning, justify their choices mathematically, and question the choices put forward by others. This introduction will provide students with a model of how they should work with their partners throughout the first small group activity.

Collaborative group work on matching graphs and functions (30 minutes)

Organize students into pairs or groups of three, and give each group a large sheet of paper, a glue stick, a pair of scissors, and one copy each of *Card Set A: Graphs* and *Card Set B: Functions*. Students should **not** use a calculator for this activity.

I'm going to give each group a set of graphs and functions card. They all use the cosine function.

Cut the sheets into cards. There is one blank – keep that, too.

Take it in turns to match and place cards. Place them next to each other, not on top, so that everyone can see.

When you match two cards, explain how you came to your decision.

Your partner should either explain that reasoning again in his or her own words, or challenge the reasons you gave.

You both need to be able to agree on and explain the placement of every card.

If you cannot find a card to match, then make one up yourself.

There is a slide (P-1), *Working Together*, to remind students of these instructions.

Whilst students are working, you have two tasks: to listen to the different ways that students approach the task, and to support and challenge their reasoning.

Notice students' approaches to the task.

Which aspects of the task do students find difficult? Which information do they first use to sort the cards? Which features do they use to match the cards? Are they able to interpret the period of the function, and relate this to the algebraic formula? Do they question each other's reasoning? You can use this information to focus whole-class discussion towards the end of the lesson.

Support and challenge students' reasoning.

Try not to tell the students how to do the task at this stage. Instead, ask questions to help them clarify their own reasoning. The questions in the *Common issues* table may be helpful.

In particular, when a student places a card, ask another student to justify the placement. This should help students to understand that the purpose of the task is for them to share their reasons for placing cards, rather than just correctly matching pairs.

We suggest that if you need to split this lesson between two teaching periods, you break at this point. Give each group of students a paper clip and ask them to clip any unglued cards to their posters. You can then resume the lesson with the next collaborative activity.

Collaborative group work on matching graphs and descriptions (20 minutes)

Project the slide *The Ferris Wheel* (P-2) onto the board.

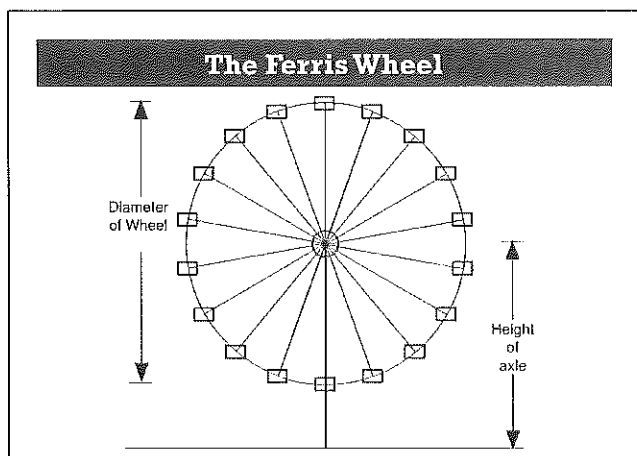

Give each pair of students a copy of *Card Set C: Descriptions of the Wheels*.

Each of the functions you have been looking at models the motion of a Ferris wheel.

I now want you to try to match the correct wheel description to the graphs and functions on the table.

On these graphs the heights are given in meters and the times in seconds.

Matching these cards will encourage students to think about the motion of a wheel.

As you watch students working, ask them to explain the connections they find:

How is the height of the axle related to the graph?

How is the speed of rotation related to the graph?

How is the diameter of the wheel related to the graph?

How is the height of the axle related to the algebraic function?

How is the speed of rotation related to the algebraic function?

How many degrees per second does this wheel turn through?

How is the diameter of the wheel related to the algebraic function?

Why do both these functions fit this graph?

Why do we have two graphs with the same description?

What is different about the graphs?

Whole-class discussion (25 minutes)

Organize a discussion about what has been learned. The intention is that you focus students on describing the relationships between the different representations, rather than checking that everyone gets the correct matches for cards.

Sheldon, where did you place this card? How did you decide?

Howard, put that into your own words.

Ask students to come up with a general explanation of how to decide which function goes with which situation.

Suppose I wrote down the function $h = a - b \cos t$.

What can you tell me about the Ferris Wheel?

[Height of axle = a ; diameter of wheel = $2b$; turns once every 360 seconds.]

Suppose I wrote down the function $h = a - b \cos 2t$.

What can you tell me about the Ferris Wheel?

[Height of axle = a ; diameter of wheel = $2b$; turns once every 180 seconds.]

You may find it helpful to project the following diagram, which is reproduced on slide P-3, *Analyzing the Ferris Wheel*, to help students explain the analytical connection between the geometry of the situation and the function $h = a - b \cos ct$.

The diagram shows the position of a rider, P , at some time during the ride.

Height of the axle = $OA = a$

Radius of the wheel = $OP = b$

At this time, suppose the angle $POA = x$

As P goes round steadily, then $x = ct$ for some constant c .

($c = 1$, wheel turns round once after 360 seconds; $c = 2$, wheel turns round once every 180 seconds, and so on.)

The height of the rider = $PB = OA - OP \cos x$

So $h = a - b \cos ct$

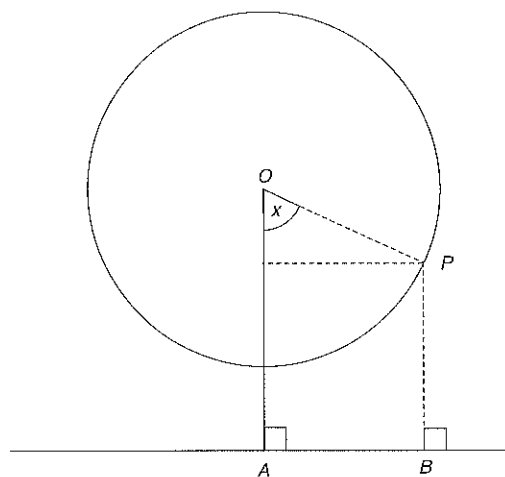

Follow-up lesson: Review of work on Ferris Wheel (20 minutes)

This work can be done either in a follow up lesson, or for homework.

Re-issue students with their individual work on *Ferris Wheel* and give each student a copy of the similar task *Ferris Wheel (revisited)*.

Ask students to work individually to revise their work on the *Ferris Wheel* task, using the questions you have written on the board or on their work, for support.

Read through your solution to Ferris Wheel, and answer the questions on the board/on your script.

Make some notes on what you have learned during the lesson.

Ask students to attempt the second task:

Now try to answer the questions on the second sheet: Ferris Wheel (revisited).

Can you use what you have learned to answer these questions?

SOLUTIONS

Assessment task: *Ferris Wheel*

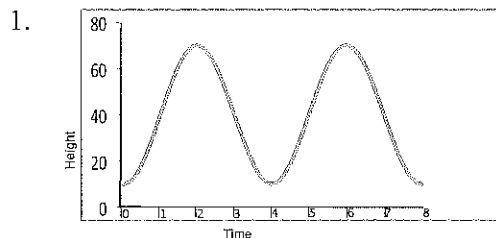

The graph of the Ferris Wheel's motion shows how height varies periodically over time. It should show that:

The graph has y -intercept $(0, 10)$ as the passenger starts at the bottom.

The amplitude is 60m, the diameter of the wheel. Minimum value of the function = 10m, maximum = 70m.

The wheel rotates once every 4 minutes, so the minima / maxima are 4 minutes apart.

The graph is a smooth curve.

2. The function that models the situation is $h = 40 - 30 \cos 90 t$.

This is of the form $h = a + b \cos ct$, where:

$a = 40$ m. This is the height of the axle of the Ferris Wheel.

$b = -30$ m. The magnitude of this number is the radius of the wheel. The person's height starts 30m below the axle, rising to 30m above the axle. The sign is negative because the person starts at the bottom (when $t = 0$, $h = 40 - 30$).

$c = 90$. This is the rate of turn in degrees per minute. To ensure that the wheel turns once every 4 minutes, we obtain c by dividing 360° by 4.

Since the minimum and maximum value of the cosine function are -1 and $+1$, the minimum and maximum values of h are $a - b$ (10m) and $a + b$ (70m) as required.

Assessment task: *Ferris Wheel (revisited)*

The task is structurally similar to the initial assessment task; all that has changed is the values of the parameters.

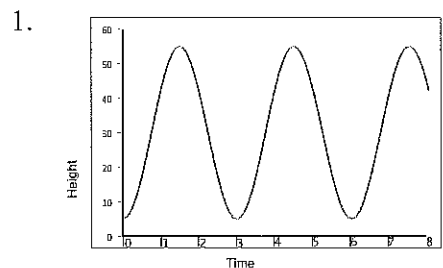

2. $h = 30 - 25 \cos 120t$

Lesson task: Card Sort

When matching cards, students may work in either direction: from graph to function, or function to graph.

For example:

Graph A immediately shows that the wheel has a diameter of 60 meters (it rises from 10m to 70m) and the axle height is thus 40m (the mean of 10m and 70m).

So this implies that in the function $h = a + b \cos ct$, $a = 40$ and $b = -30$.

The graph shows the wheel turns 2.5 times in one minute. This is a rate of $2.5 \times 360/60 = 15$ degrees per second. Thus $c = 15$. So the function that fits is: $h = 40 - 30 \cos 15t$ (Card 4).

Function $h = 60 - 20 \cos 15t$ (card 6) may be interpreted as having an axle height of 60m, and diameter of 40 m (it rises from $60-20$ to $60+20$) and the wheel turns once every $360/15 = 24$ seconds; or 2.5 times per minute. This fits with graph C.

Graph	Function	Description
A	Card 4: $h = 40 - 30 \cos 15t$	Card 3: Diameter of wheel = 60 m Height of axle above ground = 40 m Number of turns per minute = 2.5
B	Card 10: $h = 60 - 30 \cos 15t$ The student has to write this function.	Card 2: Diameter of wheel = 60 m Height of axle above ground = 60 m Number of turns per minute = 2.5
C	Card 6: $h = 60 - 20 \cos 15t$ Card 8: $h = 60 + 20 \cos (15t + 180^\circ)$	Card 1: Diameter of wheel = 40 m Height of axle above ground = 60 m Number of turns per minute = 2.5
G	Card 2: $h = 60 + 20 \cos 15t$	
D	Card 3: $h = 40 - 30 \cos 18t$ Card 9: $h = 40 + 30 \cos (18t + 180^\circ)$	Card 4: Diameter of wheel = 60 m Height of axle above ground = 40 m Number of turns per minute = 3
E	Card 1: $h = 40 + 30 \cos 18t$	
F	Card 5: $h = 60 + 20 \cos 18t$	Card 6: Diameter of wheel = 40 m Height of axle above ground = 60 m Number of turns per minute = 3
H	Card 7: $h = 40 + 20 \cos 18t$	Card 5: Diameter of wheel = 40 m Height of axle above ground = 40 m Number of turns per minute = 3

On the next page there is a photograph of a poster made using these cards.

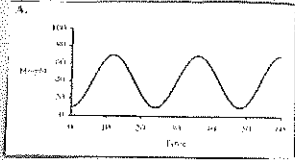

4.

$$h = 40 - 30 \cos 15t$$

3.
 Diameter of wheel = 60 m
 Height of axle above ground = 40 m
 Number of turns per minute = 2.5

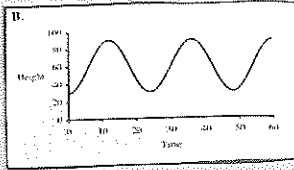

$$h = 60 - 30 \cos 15t$$

2.
 Diameter of wheel = 60 m
 Height of axle above ground = 60 m
 Number of turns per minute = 2.5

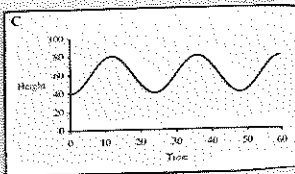

6.

$$h = 60 - 20 \cos 15t$$

8.

$$h = 60 + 20 \cos (15t + 180^\circ)$$

1.
 Diameter of wheel = 40 m
 Height of axle above ground = 60 m
 Number of turns per minute = 2.5

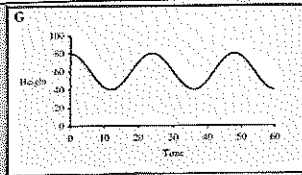

2.

$$h = 60 + 20 \cos 15t$$

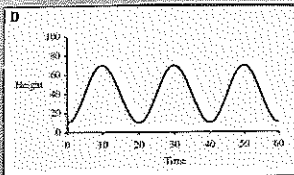

3.

$$h = 40 - 30 \cos 18t$$

9.

$$h = 40 + 30 \cos (18t + 180^\circ)$$

4.
 Diameter of wheel = 60 m
 Height of axle above ground = 40 m
 Number of turns per minute = 3

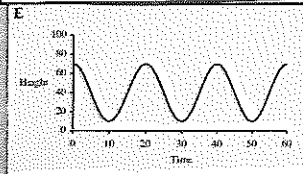

1.

$$h = 40 + 30 \cos 18t$$

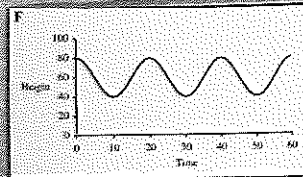

5.

$$h = 60 + 20 \cos 18t$$

6.
 Diameter of wheel = 40 m
 Height of axle above ground = 60 m
 Number of turns per minute = 3

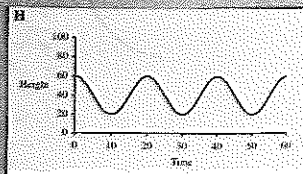

7.

$$h = 40 + 20 \cos 18t$$

5.
 Diameter of wheel = 40 m
 Height of axle above ground = 40 m
 Number of turns per minute = 3

Ferris Wheel

A Ferris Wheel is 60 meters in diameter and rotates once every four minutes.

The center axle of the Ferris Wheel is 40 meters from the ground.

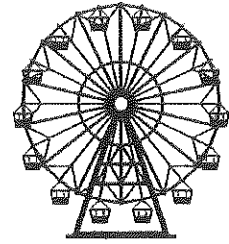

- Using the axes below, sketch a graph to show how the height of a passenger will vary with time. Assume that the wheel starts rotating when the passenger is at the bottom.

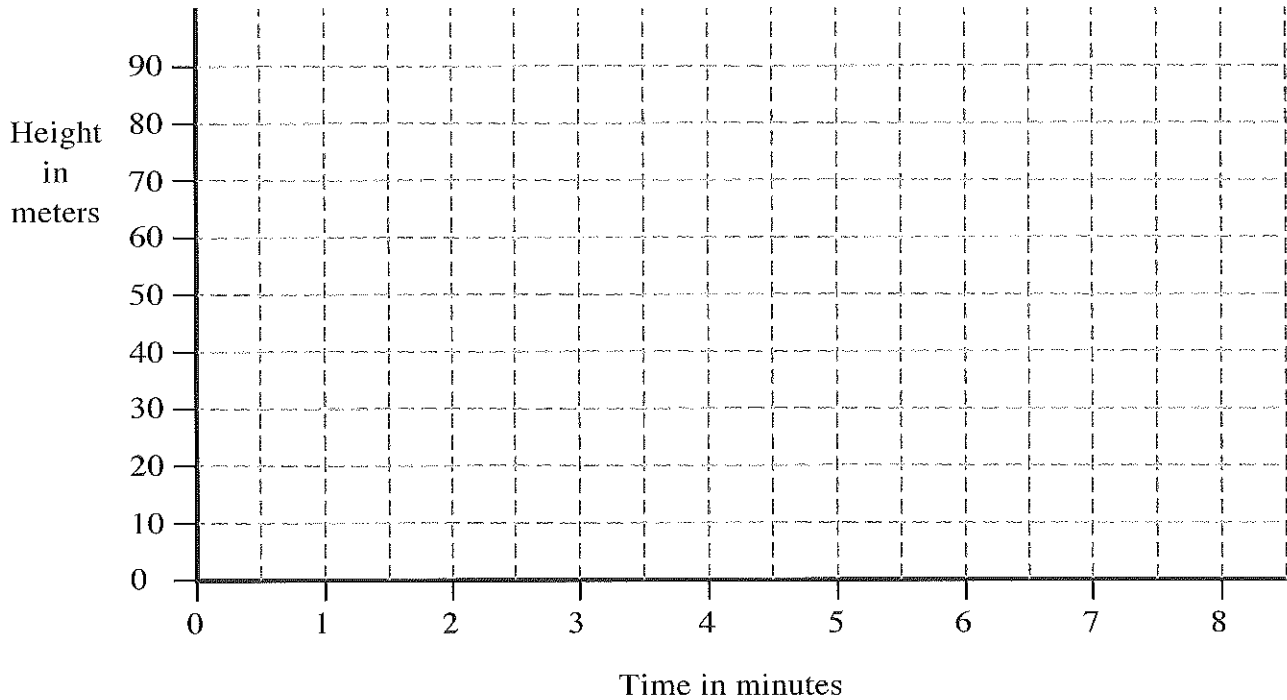

- A mathematical model for this motion is given by the formula:

$$h = a + b \cos ct$$

where

h = the height of the car in meters

t = the time that has elapsed in minutes

a, b, c are constants.

Find values for a, b and c that will model this situation.

.....

.....

.....

.....

.....

Card Set A: Graphs

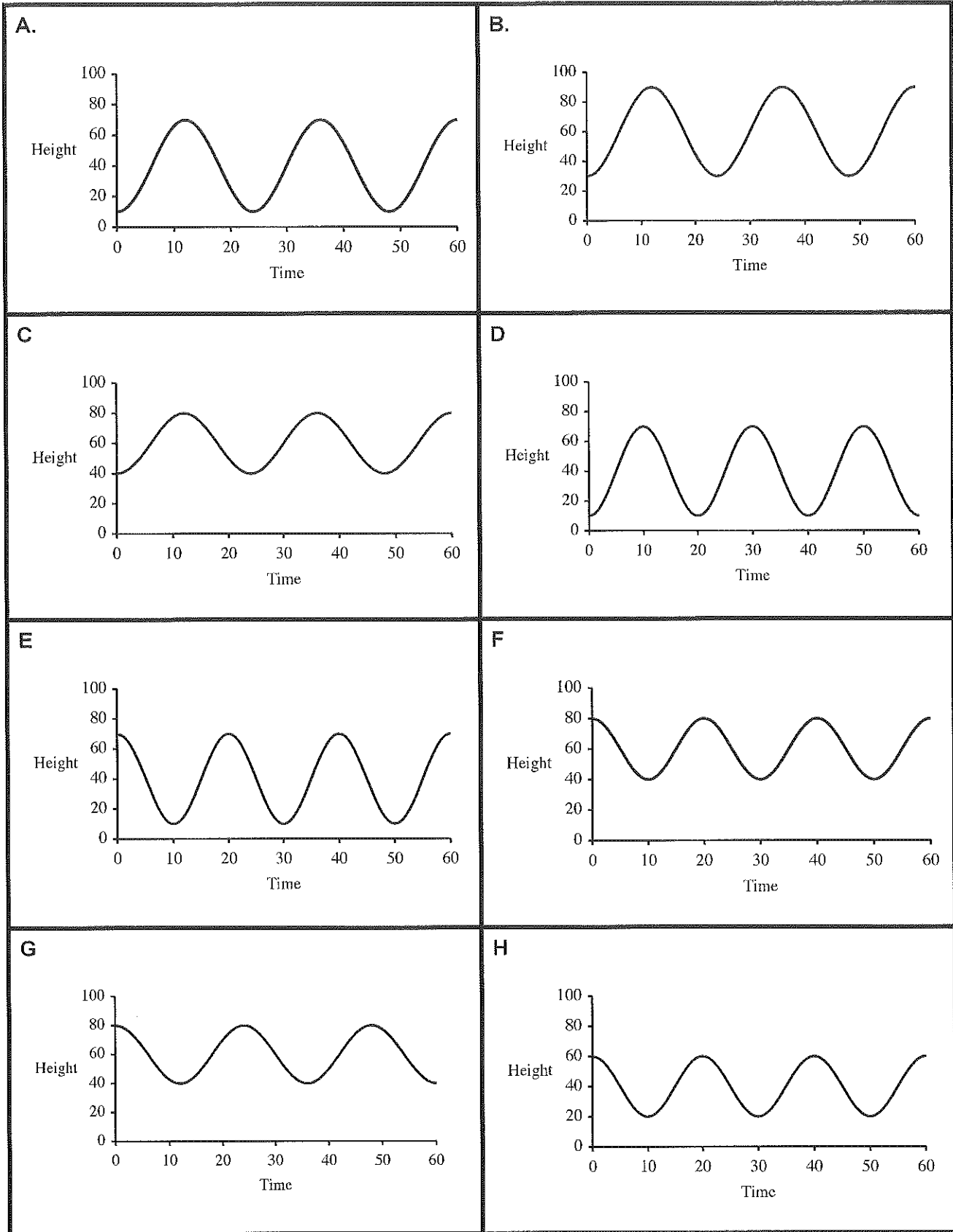

Card Set B: Functions

1. $h = 40 + 30 \cos 18t$	2. $h = 60 + 20 \cos 15t$
3. $h = 40 - 30 \cos 18t$	4. $h = 40 - 30 \cos 15t$
5. $h = 60 + 20 \cos 18t$	6. $h = 60 - 20 \cos 15t$
7. $h = 40 + 20 \cos 18t$	8. $h = 60 + 20 \cos (15t + 180^\circ)$
9. $h = 40 + 30 \cos (18t + 180^\circ)$	10.

Card Set C: Descriptions of the wheels

<p>1.</p> <p>Diameter of wheel = 40 m Height of axle above ground = 60 m Number of turns per minute = 2.5</p>	<p>2.</p> <p>Diameter of wheel = 60 m Height of axle above ground = 60 m Number of turns per minute = 2.5</p>
<p>3.</p> <p>Diameter of wheel = 60 m Height of axle above ground = 40 m Number of turns per minute = 2.5</p>	<p>4.</p> <p>Diameter of wheel = 60 m Height of axle above ground = 40 m Number of turns per minute = 3</p>
<p>5</p> <p>Diameter of wheel = 40 m Height of axle above ground = 40 m Number of turns per minute = 3</p>	<p>6.</p> <p>Diameter of wheel = 40 m Height of axle above ground = 60 m Number of turns per minute = 3</p>

Ferris Wheel (revisited)

A Ferris Wheel is 50 meters in diameter and rotates once every three minutes.

The center axle of the Ferris Wheel is 30 meters from the ground.

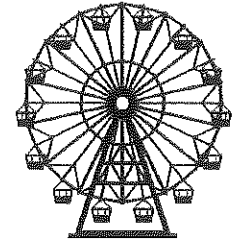

1. Using the axes below, sketch a graph to show how the height of a passenger will vary with time. Assume that the wheel starts rotating when the passenger is at the bottom.

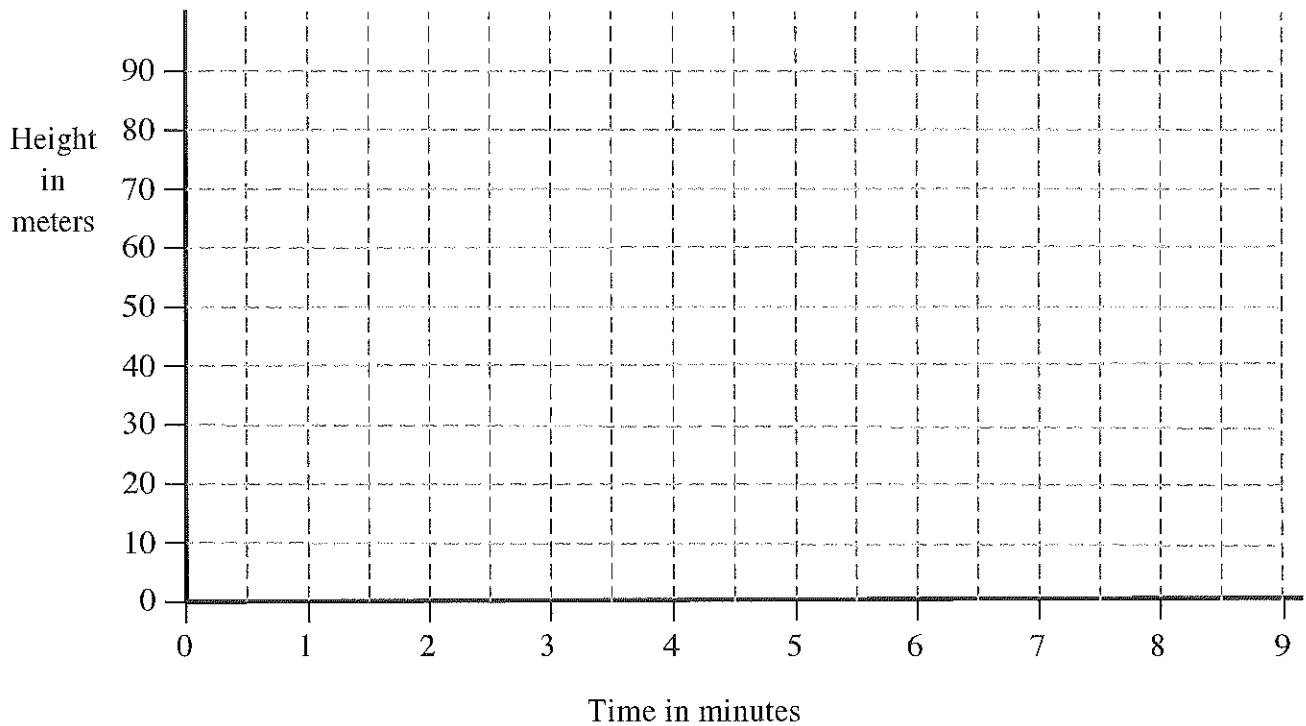

2. A mathematical model for this motion is given by the formula:

$$h = a + b \cos ct$$

where

h = the height of the car in meters

t = the time that has elapsed in minutes

a, b, c are constants.

Find values for a, b and c that will model this situation.

Working Together

- Take turns to match and place cards.
- When you match two cards:
 - Place cards next to each other so that everyone can see.
 - Explain carefully how you came to your decision.
- Your partner should either explain that reasoning again in his or her own words, or challenge the reasons you gave.
- You both need to be able to agree on and explain the placement of every card.
- If you cannot find a card to match, then make one up yourself.

The Ferris Wheel

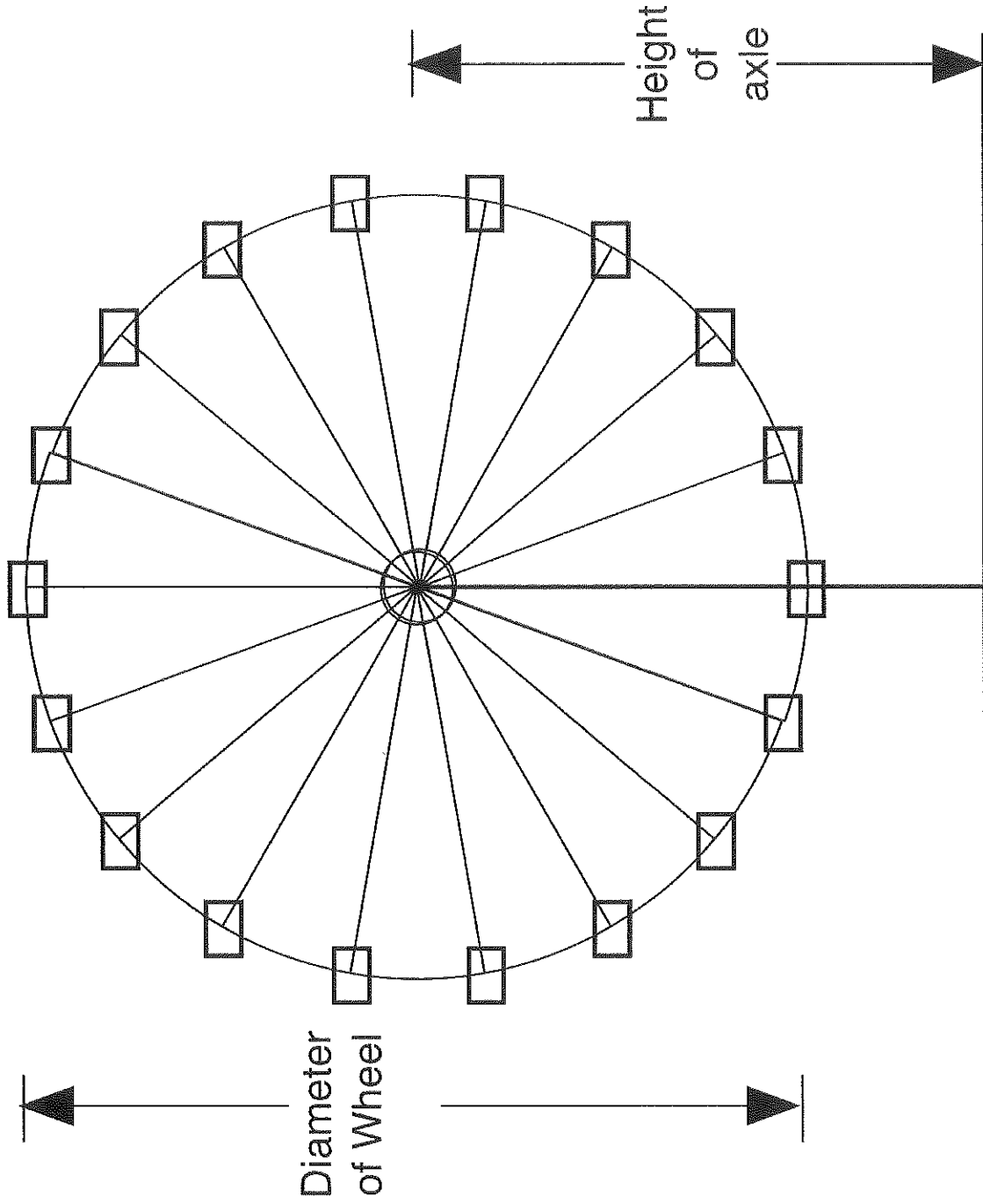

Analyzing the Ferris Wheel

The diagram shows the position of a rider, P, at some time during the ride.

Height of the axle = $OA = a$

Radius of the wheel = $OP = b$

Angle $POA = x$

As P goes round,
then $x = ct$ for some constant c .

Height of the rider

= PB

= $OA - OP \cos x$

So $h = a - b \cos ct$

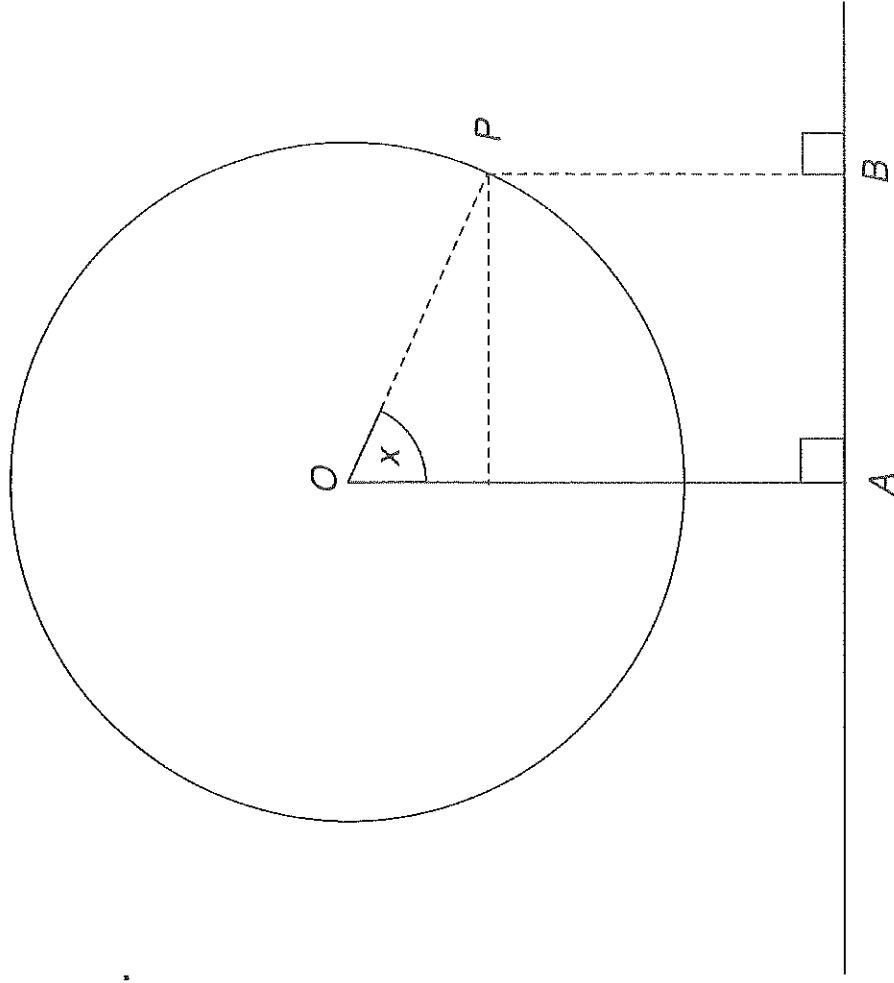

Mathematics Assessment Project
CLASSROOM CHALLENGES

This lesson was designed and developed by the
Shell Center Team
at the
University of Nottingham
Malcolm Swan, Nichola Clarke, Clare Dawson, Sheila Evans
with
Hugh Burkhardt, Rita Crust, Andy Noyes, and Daniel Pead

It was refined on the basis of reports from teams of observers led by
David Foster, Mary Bouck, and Diane Schaefer
based on their observation of trials in US classrooms
along with comments from teachers and other users.

This project was conceived and directed for
MARS: Mathematics Assessment Resource Service
by
Alan Schoenfeld, Hugh Burkhardt, Daniel Pead, and Malcolm Swan
and based at the University of California, Berkeley

We are grateful to the many teachers, in the UK and the US, who trialed earlier versions
of these materials in their classrooms, to their students, and to
Judith Mills, Carol Hill, and Alvaro Villanueva who contributed to the design.

This development would not have been possible without the support of
Bill & Melinda Gates Foundation
We are particularly grateful to
Carina Wong, Melissa Chabran, and Jamie McKee

© 2012 MARS, Shell Center, University of Nottingham
This material may be reproduced and distributed, without modification, for non-commercial purposes,
under the Creative Commons License detailed at <http://creativecommons.org/licenses/by-nc-nd/3.0/>
All other rights reserved.
Please contact map.info@mathshell.org if this license does not meet your needs.